

MFD500

Ultrasonic Flaw Detector

Operating Manual



Mitech Inc. Ltd.

1	Introduction	4
1.1	Features of the Instrument	4
1.2	Specifications	6
1.3	Base Instrument Package	6
2	Understanding the Keypad, Menu System and Displays	7
2.1	Structure Feature	7
2.2	Screen Display	8
2.3	Keys and Rotary Knob Features	10
2.4	Menus and Functions	11
2.5	Alarm Lights	11
3	Initial Start-up	13
3.1	Power Supply	13
3.2	Connecting a Probe	13
3.3	Starting the Instrument	14
4	Operation	15
4.1	Adjusting the Display Range	15
4.2	Setting the Material Velocity	15
4.3	Setting the Display Delay	15
4.4	Selecting Probe Test Mode	16
4.5	Selecting a Rectification Mode	16
4.6	Setting the A-Scan Reject Level	18
4.7	Setting the Gain	18
4.8	Changing the Gain-Adjustment Increment (DB STEP)	18
4.9	Auto Gain Feature	19
4.10	Configuring the Gates	19
4.11	Setting the Damping Level	22
4.12	Setting the Pulse Energy Level	22
4.13	Setting the Pulse Width	23
4.14	Adjusting the Pulse Repetition Frequency (PRF)	23
4.15	Specifying the Probe Frequency	23
4.16	Specifying the Piezo Crystal Size	23
4.17	Setting the Probe X-Value	23
4.18	Probe Delay Calibration	24
4.19	Setting the Angle of Incidence	24
4.20	Magnifying the Contents of a Gate	24
4.21	Freezing the A-Scan Display	24
4.22	Setting the Display Grid	24
4.23	Selecting Units	25
4.24	Scale Setting	25
4.25	Fill function	25
4.26	Setting the Display Brightness	26
4.27	Setting the Display Color	26
4.28	Setting the A-Scan Color	26
4.29	Key Sound	27
4.30	Date and Time Setting	27
4.31	Display the System Information	27
4.32	Resetting the Instrument	27
4.33	Connecting to a Computer	28
5	Calibration and Measurement	29
5.1	Calibration with Straight- and Angle-Beam Probes	29

5.2 Calibration with Dual-Element (TR) Probes	30
5.3 Distance Amplitude Curve.....	32
5.4 Measuring with AVG/AVG	34
5.5 Curved Surface Correction	37
5.6 Flaw Sizing Feature	37
5.7 Crack Height Measuring Feature	38
5.8 Envelope Function	38
5.9 Peak Hold Feature.....	39
5.10 B-Scan Feature.....	39
5.11 Data Storage	40
6 Maintenance and Care.....	42
6.1 Care of the Instrument	42
6.2 Care of the Batteries	42
6.3 Maintenance	42
6.4 Warranty	42
6.5 Tips on Safety	42
Appendix.....	43
Appendix A: Charging the batteries	43
Appendix B: Menu Structure	45

1 Introduction

The MFD350 is an advanced digital ultrasonic flaw detector featuring a multi-color TFT LCD and a host of new features to meet challenging inspection requirements. It combines powerful flaw detection and measurement capabilities, extensive data storage, and the ability to transfer detailed inspection data to the PC via its high-speed USB port.

The instrument incorporates many advanced signal processing features including a 10MHz RF bandwidth to permit testing of thin materials, narrowband filters to improve signal to noise in high gain applications and a spike pulser to optimize penetration on thick or highly attenuating materials.

The instrument can be widely used in locating and sizing hidden cracks, voids, disbands, and similar discontinuities in welds, forgings, billets, axles, shafts, tanks and pressure vessels, turbines, and structural components.

1.1 Features of the Instrument

The instrument extends the performance and range of applications that are capable of being satisfied by a portable instrument. The quality, portability, durability, and dependability that you have come to expect from the popular Mitech MFD Series of instruments remain.

Display

Hi-resolution (320 × 240 pixels) multi-color TFT LCD Display with nine user-selectable color display schemes and brightness control provides high contrast viewing of the waveform from bright, direct sunlight to complete darkness.

The hi-resolution color LCD display with fast 60 Hz update gives an “analog look” to the waveform providing detailed information that is critical in many applications including nuclear power plant inspections.

Range

Up to 6000 mm in steel. Suitable for use on large workpieces and in high-resolution measurements.

Pulser

Pulse Energy selectable among Low, Medium and High

Pulse Repetition Frequency adjustable from 10 Hz to 1 KHz in 1 Hz increments.

Damping selectable among 100 Ω , 200 Ω and 400 Ω for optimum probe performance

Test Modes include Pulse echo, dual and thru-transmission

Receiver

Sampling: 10 digit AD Converter at the sampling speed of 160 MHz

Rectification: Positive Halfwave, Negative Halfwave, Fullwave and RF

Analog Bandwidth: 0.5MHz to 10MHz capability with selectable frequency ranges (automatically set by the instrument) to match probe for optimum performance.

Gain: 0 dB to 110 dB adjustable in selectable steps 0.1 dB, 2 dB, 6 dB, and locked.

Gates

Two fully independent gates offer a range of measurement options for signal height or distance using peak triggering.

The echo-to-echo mode allows accurate gate positioning for signals which are extremely close together.

Gate Start: Variable over entire displayed range

Gate Width: Variable from Gate Start to end of displayed range

Gate Height: Variable from 0 to 99% Full Screen Height

Alarms: Threshold positive/negative

Memory

Memory of 100 channel files to store calibration set-ups

Memory of 1000 wave files to store A-Scan patterns and instrument settings.

All the files can be stored, recalled and cleared.

Functions

- I Semiautomatic two point calibration: Automated calibration of transducer zero offset and/or material velocity
- I Flaw Locating: Live display Sound-path, Projection (surface distance), Depth, Amplitude,
- I Flaw sizing: Automatic flaw sizing using AVG/AVG or DAC, speeds reporting of defect acceptance or rejection.
- I Digital Readout and Trig. Function: Thickness/Depth can be displayed in digital readout when using a normal probe and Peam path, Surface Distance and Depth are directly displayed when angle probe is in use.
- I Both the DAC and the AVG method of amplitude evaluation are available.
- I Curved Surface Correction Feature
- I Crack Height Measure function
- I Magnify gate: spreading of the gate range over the entire screen width
- I Video Recording and play
- I Auto-gain function
- I Envelope: Simultaneous display of live A-scan at 60 Hz update rate and envelope of A-scan display
- I Peak Hold: Compare frozen peak waveforms to live A-Scans to easily interpret test results.
- I A Scan Freeze: Display freeze holds waveform and soundpath data
- I B Scan display feature

Real Time Clock

The instrument clock keeps running tracking the time.

Communication

High speed USB2.0 port.

The optional DataPro software helps manage and format stored inspection data for high-speed transfer to the PC. Data can be printed or easily copied and pasted into word processing files and spreadsheets for further reporting needs.

New features include live screen capture mode and database tracking.

Battery

Internal rechargeable Li-ion battery pack rated 7.2V at 6600 mAh
8 hours nominal operating time depending on display brightness
8-10 hours typical recharge time

Knob

Operating adjustments are easily and quickly made using the rotary knob.

1.2 Specifications

- I Range: 0 to 6000 mm, at steel velocity
- I Material Velocity: 1000 to 9999m/s
- I Display Delay: -20 to 3400 μ s
- I Probe Delay/Zero Offset : 0 to 99.99 μ s
- I Sensitivity: 110 dB max in selectable resolution 0.1, 1.0, 2.0, 6.0 dB and locked.
- I Test Modes: Pulse echo, dual element and thru-transmission
- I Pulse Repetition Frequency ranges from 10 Hz to 1000 Hz
- I Pulse Energy: Low, Medium and High
- I Damping: 100, 200, 400 ohms
- I Bandwidth (amplifier bandpass): 0.5 to 10 MHz
- I Gate Monitors: Two independent gates controllable over entire sweep range
- I Rectification: Positive halfwave, negative halfwave, fullwave, RF
- I System Linearity: Horizontal: +/-0.2% FSW, Vertical: 0.25% FSH, Amplifier Accuracy +/-1 dB.
- I Reject (suppression): 0 to 80% full screen height
- I Units: Inch or millimeter
- I Transducer Connections: BNC
- I Power Requirements: AC Mains 100-240 VAC, 50-60 Hz
- I Dimensions: 263H \times 170W \times 61D mm
- I Operating Temperature: -10 $^{\circ}$ C to 50 $^{\circ}$ C
- I Storage Temperature: -30 $^{\circ}$ C to 50 $^{\circ}$ C

1.3 Base Instrument Package

Portable Ultrasonic Flaw Detector with Hi-Resolution Color LCD Display
Straight Beam Transducer (2.5 MHz, Φ 20)
Angle Beam Transducer (2.5 MHz, 13 mm \times 13 mm, 63.5 $^{\circ}$)
Interconnect Cable for the transducer (Q9-Q9)
Rechargeable Li-Ion Battery Package, 6.6 amp hour
Power supply/charger unit
Supporting pillar
Operating Manual in English

2 Understanding the Keypad, Menu System and Display

2.1 Structure Feature

The right figure gives an overview of the instrument system.

- 1、 The Main Unit
- 2、 Probe (Transducer)

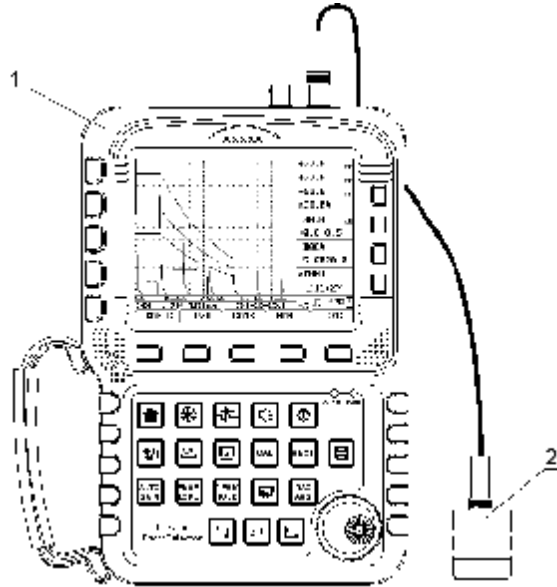

The Main Unit

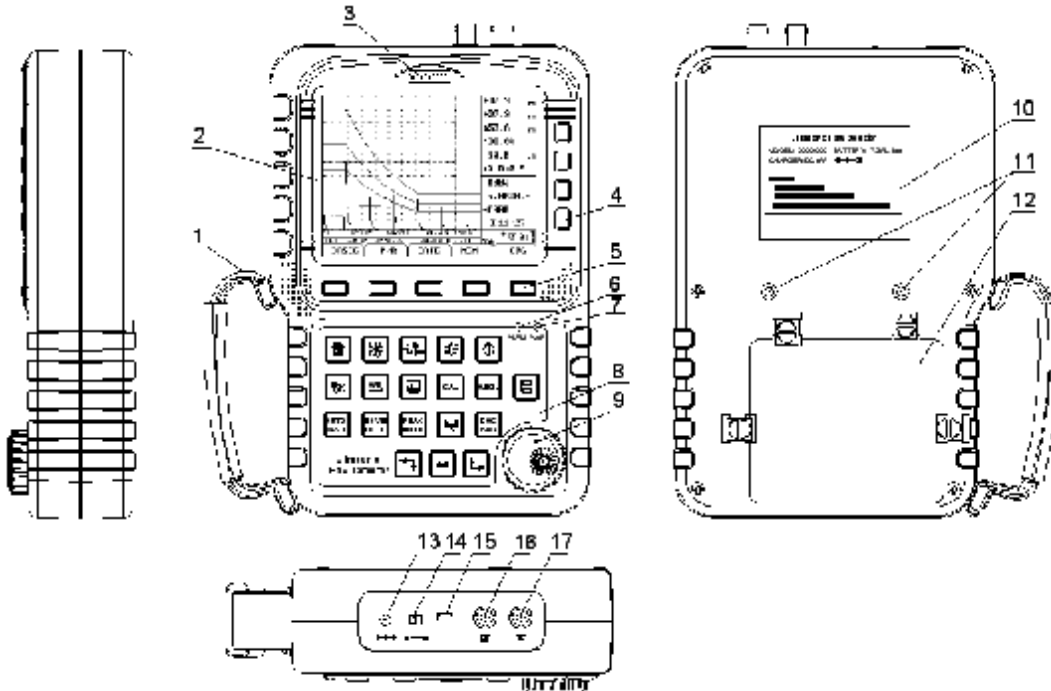

- | | | | | |
|---------------------------------|-------------------------------|------------------|------------------|-------------|
| 1, Belt | 2, LCD Display | 3, LOGO | 4. Function Keys | 5 Menu Keys |
| 6, Alarm LED | 7, Power LED | 8, Keypad | 9, Rotary Knob | |
| 10, Product Label | 11, Support Pillar Screw | 12, Battery Case | | |
| 13, Power adapter port | 14, Battery Switch | 15, USB Socket | | |
| 16, Probe Cable Port (Transmit) | 17, Probe Cable Port(Receive) | | | |

2.2 Screen Display

The instrument displays are designed to be easy to interpret.

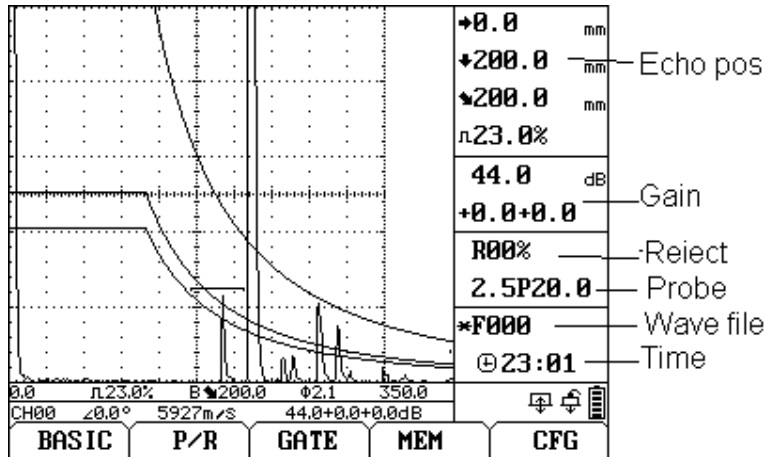

The Instrument has a digital screen for the display of A-Scan. Top figure shows the main screen.

The names of the menus or submenus are displayed at the bottom of the screen. The selected menu or submenu is highlighted.

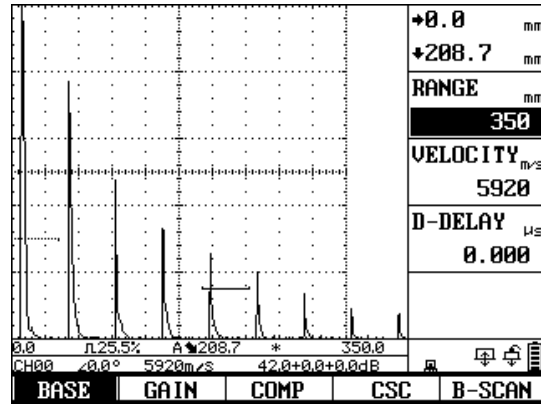

Indicated at the right of the display, next to the A-Scan, are the functions of the corresponding menu. The display of the functions disappears on the home screen.

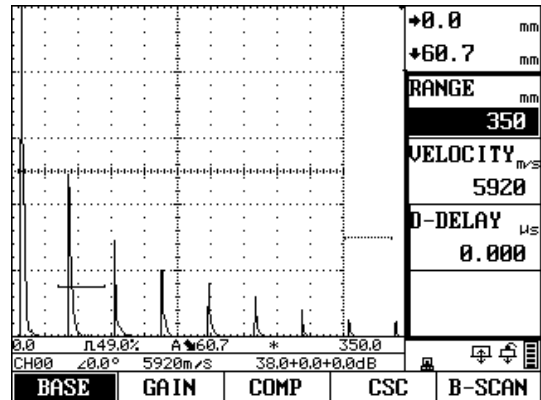

The measurement line below the wave display shows values of range settings and measured values.

π: Amplitude height. * : Sound path.

➤: Projection. ⚡: Depth

“A π61.3” means gate mode is single; selected gate is gate A; and peak echo position: sound path 61.3 mm.

“AB *24.0” means Echo-Echo mode; selected gate is gate A; soundpath: 24.0 mm.

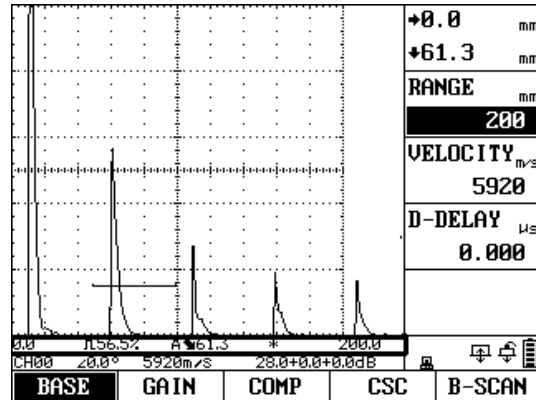

The setting line below the measurement line shows the channel file name, the beam angle, the velocity and the gain.

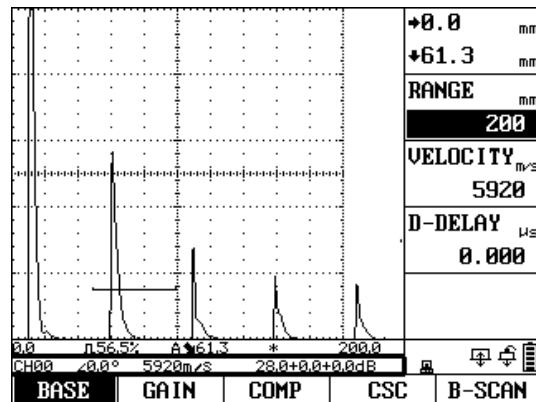

The status area at the bottom-right corner shows the system status. The following status will be showed:

- 🔋: Indicates the battery capacity
- 📶: Straight beam probe
- 📶: Angle beam probe
- 📶: Single element probe
- 📶: Dual element probe
- 📶: Through-transmit mode
- 📶: Envelope function on
- 📶: Peak hold function on
- 📶: USB online; * : A-Scan frozen

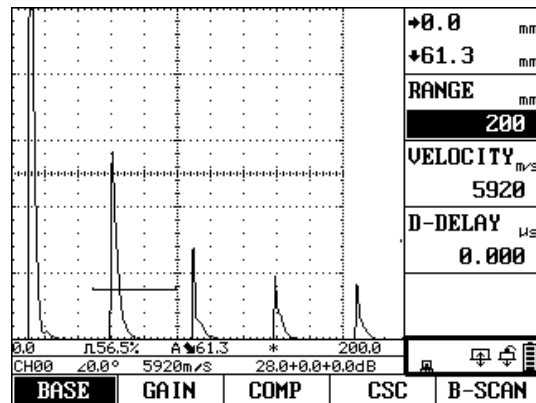

The echo position area at the top-right corner indicated shows the projection and the depth of the peak echo.

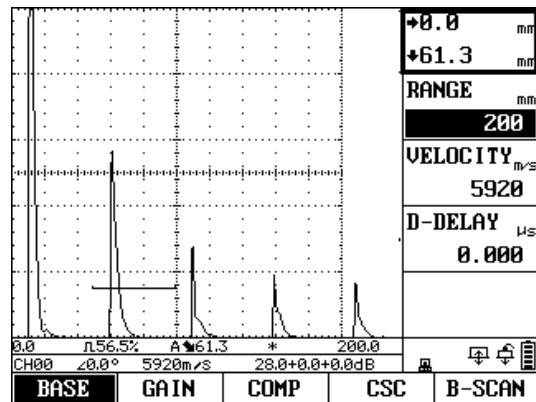

2.3 Keys and Rotary Knob Features

The instrument is designed to give the user quick access to all of the instrument's functions. Its easy-to-use menu system allows any function to be accessed with no more than three key presses.

To access any function:

- I Press one of the five menu keys (F1~F5) to select a menu. The menus across the bottom of the display will immediately be replaced with the submenus contained in the selected menu.
- I Press a menu key (F1~F5) again to select the submenu containing the desired function.



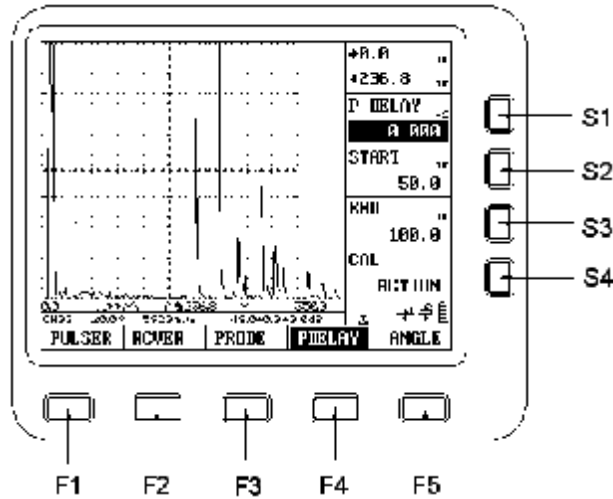



- I Up to four functions will be displayed in the function bar on the right side of the display. Select the desired function, by pressing one of the four function keys (S1~S4).

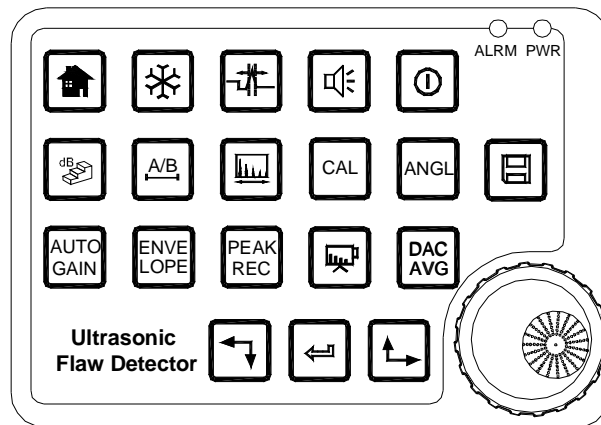













- I Change the value listed in the function box with the rotary knob. Some values can also be adjusted with repeatedly pressing the corresponding function key.

Special keys such as Gain, Gate, Range, Probe Zero-Offset Calibration, Angle Calibration, Freeze, Save Waveform, Auto-Gain, Envelop, Peak Hold and etc. are grouped together for easy thumb control. This design allows direct access to important instrument set-up parameters and provides easy and fast operating in difficult inspection environments



-  Home key immediately returns the instrument to the main screen
-  Freeze key freezes the A-Scan
-  Magnify key expands the gate range to full screen
-  Alarm key turns the gate alarm on or off
-  For turning the instrument on or off
-  Db-Step key selects the gain submenus or switch the db step
-  Gate key - Gate functions selecting gate functions and Gate A/B switch

-  Range key - Range function selecting
 -  CAL Probe-Delay key – Probe Delay calibration
 -  ANGL Probe-Angle key selects the angle calibration functions
 -  Save key performs a data-storage of the A-Scan pattern
 -  AUTO GAIN Auto-Gain key starts or stops the Auto-Gain function
 -  ENVELOPE Envelope key turns the Envelope function on and off
 -  PEAK REC Peak-Hold key turns the Peak-Hold function on and off.
 -  Video key starts or stops recording a segment of the display
 -  DAC-AVG key selects the menus of DAC/AVG
 -  searches next echo towards left, or move the cursor to left when inputting digit numbers.
 -  searches next echo towards right, or move the cursor to right when inputting digit numbers.
 -  confirms or switches current selection
- Rotary knob: For direct setting the currently selected function. A single key press on the rotary knob will function as pressing .

2.4 Menus and Functions

The instrument menu system consists of several menus, submenus, and functions. It allows the operator to select and adjust various features and instrument settings.

- I Available menus are accessed via the Home Menu. Note that the menus visible on your particular instrument depend on which options are installed.
- I Each menu contains several submenus.
- I Menus and submenus are selected by pressing the key below the desired item (F1 to F5).
- I When a submenu is selected, the functions contained in that submenu are listed in the Function Bar down the right-hand side of the display screen.
- I Functions are then selected by pressing the adjacent Function Key (S1 to S4).
- I Turning the Function Knob, and in some cases continuing to press the adjacent Function Key, will change the value shown in the selected function's box.

Note that some functions, like RANGE, have both coarse and fine adjustment modes. Coarse and fine modes are selected by pressing the adjacent Function Key more than once. An icon of “” will appear on the left of the function name when the function is in fine adjustment mode. When the function is in coarse adjustment mode, turning the function knob will produce large changes in the selected function's value. When the function is in fine adjustment mode, turning the function knob will change the value by smaller amounts.

2.5 Alarm Lights

Two alarm lights appear at the top-right corner front of the instrument's keypad. One alarm light is marked as ALRM, which is assigned to the gate alarm. When a gate alarm is triggered, this light will illuminate. The other light is marked as PWR indicating power and battery status.

Status	ALRM LED	PWR LED
Gate alarm	Red on	×
Battery charging	×	Flash red/green
Battery charged with external power connected	×	Green on
External power connected No battery installed	×	Green on
No external power	×	off

3 Initial Start-up

3.1 Power Supply

The instrument can be operated with an external power adapter or with batteries.

You can connect the instrument to the mains supply system even if it carries batteries. A discharged battery is charged in this case, viz. parallel to the instrument operation.

Operation Using the Power Supply Unit

Connect the instrument to the mains socket-outlet using the power supply unit. The plug receptacle is at the top left of the instrument. Push the plug of the power supply unit into the plug receptacle until it snaps into place with a clearly audible click. The PWR LED on the keypad of the instrument will light in green color if the connection is properly aligned

Operation Using Batteries

Use a lithium-ion battery pack provided with the instrument for the battery operation.

The battery compartment is situated at the instrument back. The lid is fastened with 4 attachment block. To insert the battery pack

- I Move the four attachment block of the battery compartment downward in order to loosen them.
- I Lift the lid off upward. At the bottom of the battery compartment, you will see two springs.
- I Insert the battery into the battery compartment. Make sure that the two contacts on the back of the battery pack are connected with the springs in the battery compartment.
- I Close the battery compartment and fasten the attachment blocks.
- I Check the battery switch on the top of the instrument. Make sure to switch it on before internal charging.

Note:

- I The battery switch on the top of the instrument must be set to ON when operating with the battery pack or charging it.
- I When not using the instrument, set the switch to OFF to save power.

3.2 Connecting a Probe

To prepare the instrument for operation, you have to connect a probe to it. The instrument is available with the probe connectors BNC.

When connecting a probe to the instrument, it's not only important that the probe's physical connection be properly made. It's also important that the instrument is properly configured to work with the installed probe. The Instrument will operate with one or two single-element probes or with a dual-element probe.

To install a single-element probe, connect the probe cable to either of the two ports on the front of the instrument. When two probes, or a dual-element probe is connected to the instrument, the "Receive" probe connector should be installed in the right port and the 'Transmit' probe connector in the left port.

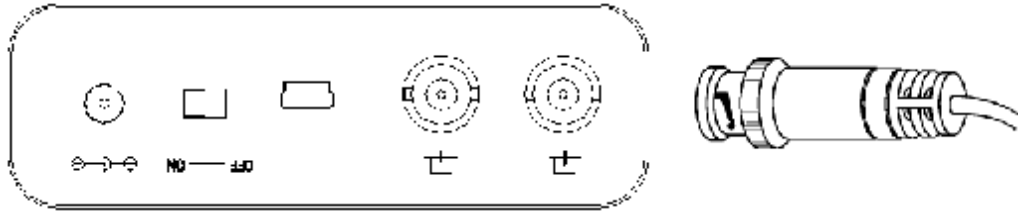

Connect one single element probe to either port.
 Connect leads from a Dual Element Probe to both ports.
 For through-transmission, connect two single element probes to the transmit (left, labeled as $\boxed{+}$) and receive (right, labeled as $\boxed{+}$) ports.

3.3 Starting the Instrument

To start the instrument, press the switch-on key $\boxed{\text{O}}$. If it operates on the internal battery pack, make sure to set the battery switch to ON position before starting. The start display of the instrument appears; here you will also see the current software version and the serial number of the instrument. The instrument carries out a self-check and then switches over to stand-by mode. The settings of all function values are the same as before switching-on of the instrument. The instrument will shut off automatically when the battery capacity level is too low.

4 Operation

4.1 Adjusting the Display Range

The function group BASE enables you to make the basic adjustment of the display range. The display on the screen must be adjusted for the material to be tested and for the probe used.

Calibration requires the use of calibrated standard made of the same material as the test piece. Prior to calibrating the instrument/probe combination, the A-Scan display-screen range (the material thickness value represented by the full horizontal width of the screen) will normally be set to a value equal to or slightly larger than the calibrated standard.

- Activate the BASE submenu (located in the BASIC menu) by pressing the menu key below it. Three functions will appear down the right side of the display screen.
- Press the function key next to the selection titled RANGE. You'll note that RANGE has both coarse and fine adjustment modes. Coarse and fine modes are selected by repeatedly pressing the corresponding function key next to it.
- To change the range, turn the knob. Note that the maximum of range setting is 6000 mm.
- The display's horizontal range will remain as set.

Range is selectable in fixed steps or continuously variable.

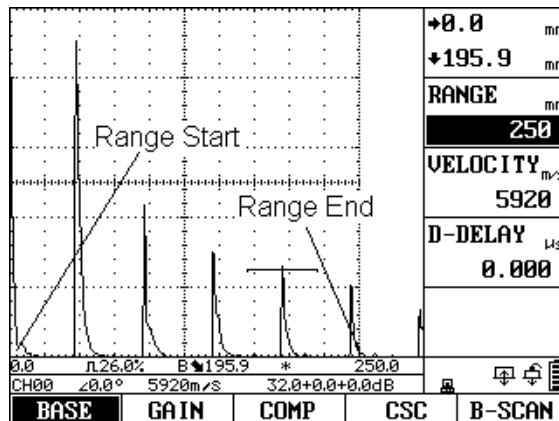

4.2 Setting the Material Velocity

Use VELOCITY to set the sound velocity within the test object. Always ensure that the function VELOCITY is correctly set. The instrument calculates all range and distance indications on the basis of the value adjusted here.

Velocity range: 1000m/s~9999m/s

Coarse adjustment, in steps as follows :

2260m/s 2730m/s 3080m/s 3230m/s
4700m/s 5920m/s 6300m/s

Fine adjustment: 1000~9999 in steps of 1 m/s

4.3 Setting the Display Delay

Here you can choose whether to display the adjusted range (for example 300 mm) starting from the surface of the test object, or in a section of the test object

starting at a later point. This allows you to shift the complete screen display and consequently also the display zero. If the display should for example start from the surface of the test object, the value in D-DELAY must be set to 0. To set the display delay

- Activate the BASE submenu (located in the BASIC menu) by pressing the menu key below it. Three functions will appear down the right side of the display screen.
- Press the function key next to the selection titled D-DELAY.
- To change the display delay, turn the knob. You'll note that the displayed echoes shift to the left or right.

Range: -20~3400 μ s

Coarse adjustment: 10 pixel space (in μ s)

Fine adjustment: 1 pixel space (in μ s)

4.4 Selecting Probe Test Mode

You can use the function PRB MODE to activate the pulser-receiver separation. The following modes are available:

- I SINGLE- For single-element operation (☐ will be displayed); the probe connection sockets are connected in parallel.
- I DUAL – For the use with dual-element (TR) probes (☐ will be displayed); the right-hand socket is connected with the amplifier input whereas the initial pulse is available at the left-hand socket.
- I THRU – Through-transmission mode for the use with two single-element probes (☐ will be displayed); the receiver is connected with right, the pulser is connected with left.
- Activate the RCVER submenu (located in the P/R menu) by pressing the menu key below it.
- Press the function key next to the selection titled PRB MODE.
- To change the probe mode, turn the knob. Each available probe mode is represented by an icon that's displayed near the down-right corner of the display whenever that probe mode is indicated.
- The probe mode will be set to the last one displayed.

4.5 Selecting a Rectification Mode

You can select the rectification mode of the echo pulses according to your application in the function RECTIFY.

Rectification effects the orientation of the A-Scan on the display screen. The A-Scan represents the pulse (echo) that's returned from the material being tested to the instrument. The series of echoes looks like the Radio Frequency (RF) signal.

Note that the RF signal has a negative component below the axis, and a positive component above the axis. RF rectification is useful when evaluating a probe. RF rectification is forbidden when displaying the DAC/AVG curves.

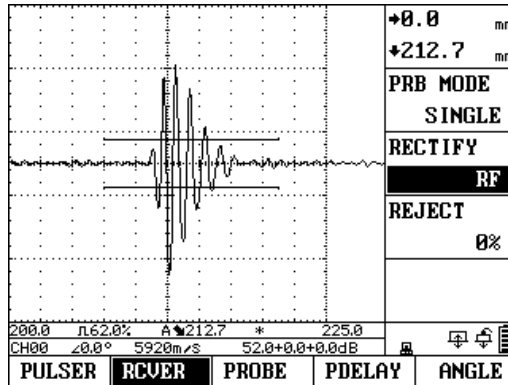

Positive Half Rectification means that only the upper (positive) half of the RF signal is displayed.

Negative Half Rectification means that only the bottom (negative) half of the RF signal is displayed. In the figure above, note that even though it's the negative half of the RF signal, it's displayed in the same orientation as a positive component. This is only to simplify viewing. The signal displayed in the view identified as Negative Rectification is the negative component of the RF signal.

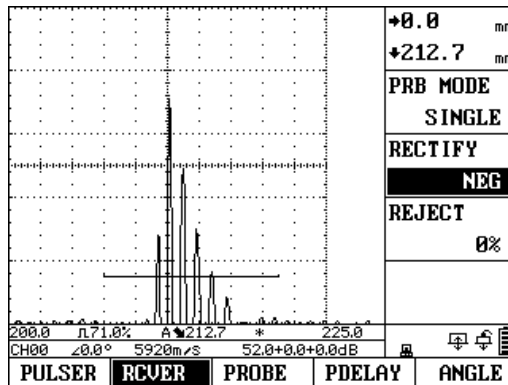

Full-Wave Rectification combines the positive and negative rectified signals together, and displays both of them in a positive orientation. Full-wave rectification is recommended for most inspections.

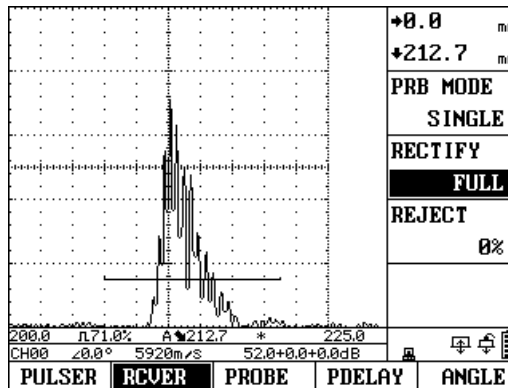

Use the following procedure to select a rectification mode

- Activate the RCVER submenu (located in the P/R menu) by pressing the menu key below it. Three functions will appear down the right side of the display screen.
- Press the function key next to the function titled RECTIFY. You'll note that there are four options:
 - ! POS- Shows the positive component of the RF signal
 - ! NEG- Shows the negative component of the RF signal but displays it in a positive orientation
 - ! FULL- Shows the positive and negative halves of the RF wave, but both are oriented in the positive direction.
 - ! RF- Shows the echo with no rectification
- Select the rectification method.

4.6 Setting the A-Scan Reject Level

The function REJECT allows you to suppress unwanted echo indications, for example structural noise from your test object. To omit a portion of the A-Scan, you must define the percentage of full-screen height you wish to omit. You may omit A-Scan up to 80% of the screen height. To Set a reject percentage

- Activate the RCVER submenu (located in the P/R Menu) by pressing the menu key below it.
- Press the function key next to the selection REJECT.
- Set the required percentage value by turning the knob.

You should handle this function with great caution, as it may of course happen that you suppress echoes from flaws as well. Many test specifications expressly forbid using the reject function.

4.7 Setting the Gain

Instrument gain, which increases and decreases the height of a displayed A-Scan, is adjusted with the gain functions.

The gain is displayed as: A+B+C dB. It includes the basic gain, the offset gain and the sensitivity correction. The maximum of the total gain (A+B+C) is 110 dB.

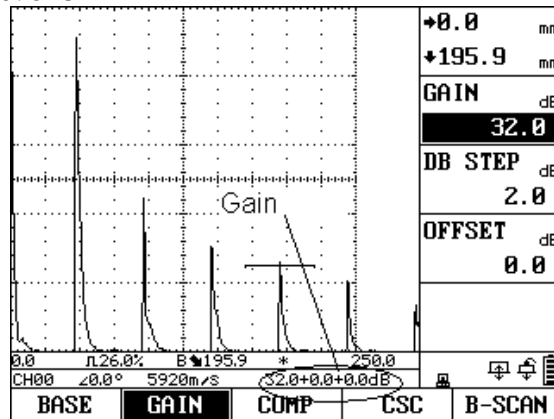

The offset gain is for the purpose of flaw evaluation. The DAC/AVG curves remain the same when adjusting the offset gain.

Sensitivity correction: Compensate for the transfer losses in the material under test. This correction is necessary if test object and reference block have different surface qualities. You have to find out the adjustment value for the compensation of transfer losses by experiments. The gain is varied accordingly in this correction, while the curve line remains the same. To set the sensitivity correction, select the function T-CORR and then adjust its value according to the experiment.

When DAC is active, adjusting the basic gain setting will result in an equal adjustment of the DAC curve position. To increase the instrument gain without changing the DAC curve position, use the T-CORR function to compensate for varying coupling/surface conditions.

4.8 Changing the Gain-Adjustment Increment (DB STEP)

When adjusting the A-Scan Gain, each click of the adjustment knob increases or decreases the gain level by a dB increment equal to the DB STEP. Several values can be specified for DB STEP. Available increments include: 0.1dB, 1dB, 2dB, 6dB and 0dB. Note that setting the DB STEP to 0dB prevents adjustment of the instrument gain and prevents any changes using the knob.



To select one of the existing DB STEP values:

- Activate the GAIN submenu (located in the BASIC menu) by pressing the menu key below it.
- Press the function key next to the selection titled DB STEP.
- Change the DB STEP value by repeatedly pressing the corresponding function key or by turning the knob.

Note that DB STEP value can be quickly changed by repeatedly pressing the key .

4.9 Auto Gain Feature

Use the Auto Gain function to automatically set the basic gain, so as to adjust the peak echo to a target height.

- Set the target echo height using the AUTO function located in the FUNC submenu.
- Press  to start the Auto Gain function. "AUTO-XX%" will be shown on the screen.
- The Auto Gain function will end when the echo height reaches the target value. Or you can stop the function by pressing  again.

4.10 Configuring the Gates

The gates monitor the range of the test object where you expect to detect a flaw. If an echo exceeds or falls below the gate, an alarm signal is sent out via the ALRM LED. The gate chooses the echo for the digital time-of-flight or amplitude measurement.

The instrument has two gates: A gate and B gate. Gate A and B are independent of one another. Setting the position and characteristics of the A- and B-Gates is the first step to configuring the instrument for flaw detecting or material-thickness measurement. The GATE menu controls not only the location of the A and B-Gates, but also the alarms and other features activated when an A-Scan signal crosses a specific gate.

A-Scan signals crossing the A or B-Gate are evaluated for the purposes of flaw detection and material-thickness evaluation. When the signal crosses the A or B-Gate, the maximum point (peak) of the signal (in the specific gate) is used for evaluation purposes. The measured value is indicated in the measurement line.

Selecting a Gate

Selecting a gate by using the GATE SEL function.

You can also repeatedly press  to switch the selected gate between Gate A and Gate B.

The selected gate will be shown in solid line. The unselected gate will be shown in dashed line.

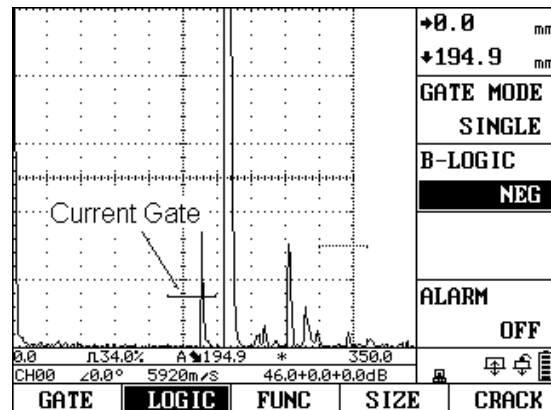

Positioning Gates

Use the following procedures to set the vertical and horizontal position of the A and B-Gates. Remember that gate position has the following effects on instrument performance:

- I A-Scan echoes on the right side of the display screen represent features that occur at a greater depth from the test-material surface than those on the left of the display screen. Therefore, moving a gate to the right means that the gate is evaluating a deeper portion of the test material.
- I A wider gate will simply span the equivalent of more test-material depth
- I Increasing the vertical height (called threshold) of a gate means that only reflected signals of sufficiently large amplitude will cross the gate.

Setting a Gate's Starting Point

You can fix the starting point of the gates A or B within the display range.



- Activate the GATE submenu (located in the GATE menu).
- Select the gate to be positioned using the GATE SEL function.
- Select the gate START function and adjust the starting point by turning the knob. Increasing and decreasing the value of the starting point moves the gate to the right and left, respectively.
- The gate starting point will remain as set, even when width adjustment is made.

Coarse adjustment: 10 pixel space

Fine adjustment: 1 pixel space

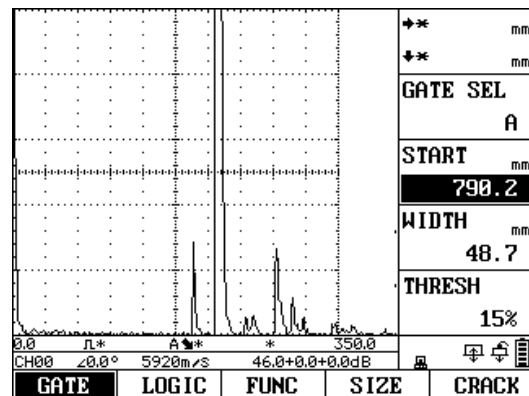
When the gate exceeds the display range, as shown in right figure, the measured value will be shown as “*” in the measurement line.



You can also set the selected gate's starting point using the Quik Search Function. Quick Search Function is achieved by simply pressing the  and . Note that the instrument will only search the echo whose peak crosses the selected gate in this function.

Adjusting a Gate's Width

You can determine the gate width within the display range.

- Activate the GATE submenu (located in the GATE menu).
- Select the gate to be positioned using the GATE SEL function.
- Select the gate WIDTH function and adjust its value by turning the knob.

Coarse adjustment: 10 pixel space

Fine adjustment: 1 pixel space

Setting a Gate's Threshold (Vertical Position)

You can determine the threshold value of the gates within the range of 0 to 99% screen height for triggering the LED alarm if this value is exceeded or not reached, depending on the setting of the LOGIC function.

- Activate the GATE submenu (located in the GATE menu).
- Select the gate to be positioned using the GATE SEL function.
- Select the THRESH function and adjust the vertical height by turning the knob. Increasing and decreasing the value of the threshold moves the gate up and down, respectively.

Defining B-Gate Alarm Logic

This function allows you to choose the method for triggering the B-Gate alarm. Gate alarms can be set to trigger when an A-Scan echo crosses the gate (POSITIVE logic) or when no echo crosses the gate (NEGATIVE logic) within the displayed range.

A-Gate is locked to POSITIVE logic. And B-Gate can be set to either POSITIVE or NEGATIVE.

The appearance is different between the POSITIVE gate and the NEGATIVE gate when displayed. This is shown in right figures.

Note that the alarm and measurement function of the gates is only active within the display range.

Use the following procedure to specify B-Gate logic:

- Activate the LOGIC submenu (located in the GATE menu) by pressing the menu key below it.
- Select the LOGIC function and choose the gate-alarm triggering logic.

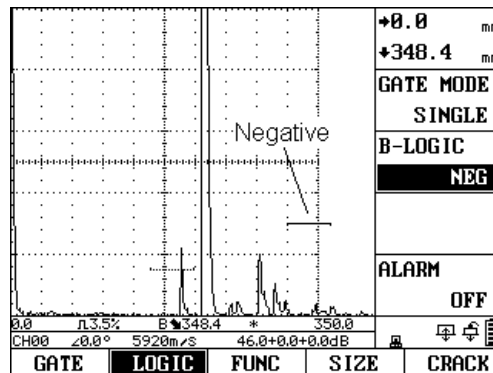
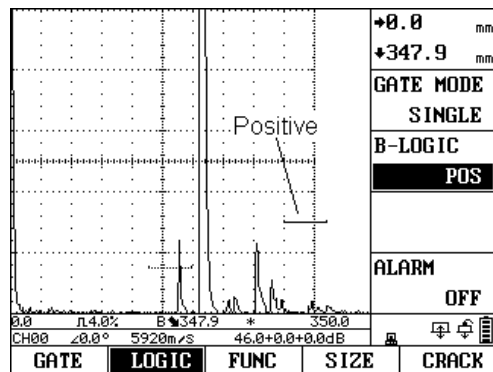

Turning the Audible Alarm On or Off

When a gate alarm is activated, one or more of the following will occur:

- I An alarm indication light on the front of the instrument will illuminate
- I An audible alarm (HORN) will sound

Use the following procedure to turn the horn off or on:

- Activate the LOGIC submenu (located in the GATE menu) by pressing the menu key below it.
- Select the ALARM function and turn the audible alarm ON or OFF.

Setting the Gate Work Mode

Two options for the gate work mode: SINGLE and E-E.

SINGLE: measures the distance from the surface to the peak echo.

E-E (Echo-Echo mode): measure the distance between two peak echoes (the two peak echoes should be selected by two gates). It is very useful in thickness measuring.

Use the GATE MODE function in the LOGIC submenu to select the gate work mode.

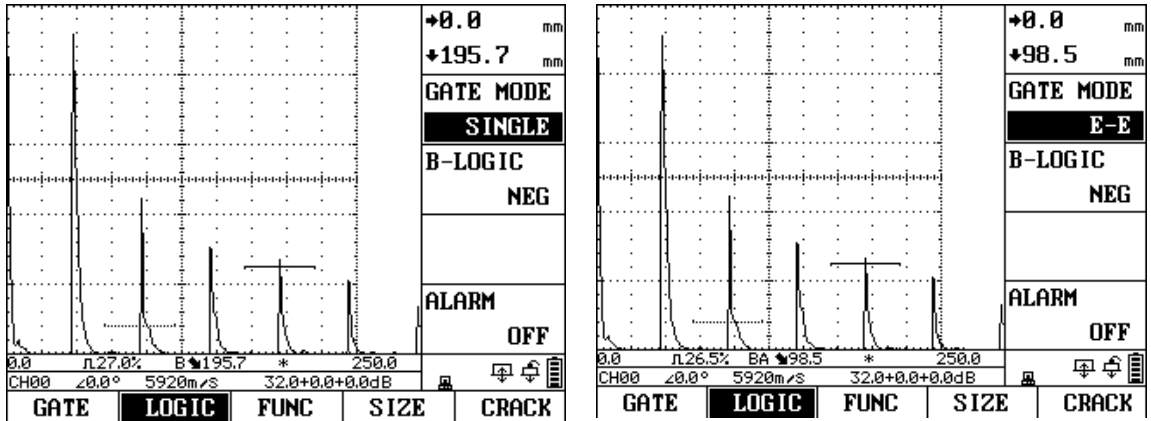

4.11 Setting the Damping Level

This function serves for matching the probe. You can use it to adjust the damping of the probe's oscillating circuit and to consequently change the height, width and resolution of the echo display.

- Activate the PULSER submenu (located in the P/R menu) by pressing the menu key below it.
- Press the function key next to the selection titled DAMPING.
- To change the specified damping level and optimize the A-Scan signal appearance, continue pressing the function key or turn the knob. You'll note that the following damping levels are available: 100Ω, 200Ω, 400Ω.
- The damping level will be set to the one last displayed.

4.12 Setting the Pulse Energy Level

Use the function ENERGY to set the pulser voltage. The relative energy with which the pulser fires can be set to LOW, MEDIUM or HIGH.

The setting MEDIUM is recommended for most inspections. HIGH is used for inspections in which maximum sensitivity is important, e.g. for the detection of small flaws. Choose the setting LOW for broadband probes or if narrow echoes are required (better lateral resolution).

To set the pulser energy

- Activate the PULSER submenu (located in the P/R menu) by pressing the menu key below it.
- Press the function key next to the function titled ENERGY.
- Select the energy level by turning the knob or continuing to press the function key.

4.13 Setting the Pulse Width

This function is Not Available for MFD350.

4.14 Adjusting the Pulse Repetition Frequency (PRF)

The pulse repetition frequency indicates the number of times an initial pulse is triggered per second. You can determine whether you need the highest possible PRF value, or whether you are satisfied with a low value.

The PRF value ranges from 10 Hz to 1000 KHz. The larger your workpiece, the smaller PRF values are needed in order to avoid phantom echoes. In the case of smaller PRF values, however, the A-Scan update rate becomes lower, for this reason, high values are required if a workpiece should be scanned fast.

The best way to determine the suitable PRF value is by experimenting: start from the highest step and reduce the value until there are no more phantom echoes.

To set the PRF level

- Activate the PULSER submenu (located in the P/R menu) by pressing the menu key below it.
- Press the function key next to the function titled PRF.
- Change the PRF value by turning the knob.

4.15 Specifying the Probe Frequency

In this function, you can specify the probe frequency according to the frequency of your probe. The instrument will automatically utilize a built-in filter to match the probe frequency.

- Activate the PROBE submenu (located in the P/R menu) by pressing the menu key below it.
- Press the function key next to the selection titled XTAL FREQ.
- To change the specified frequency, turn the knob.
- The probe frequency will be set to the last one displayed.

4.16 Specifying the Piezo Crystal Size

Use EFF DIAM function to set the Piezo Crystal Size of your probe. This value is required when programming the AVG.

4.17 Setting the Probe X-Value

The function X-VALUE enables you to set the X-Value (distance between the probe's leading face and probe index/sound exit point) of the probe used. This value is required for the automatic calculation of the reduced projection distance.

Adjustment range: 0~50 mm

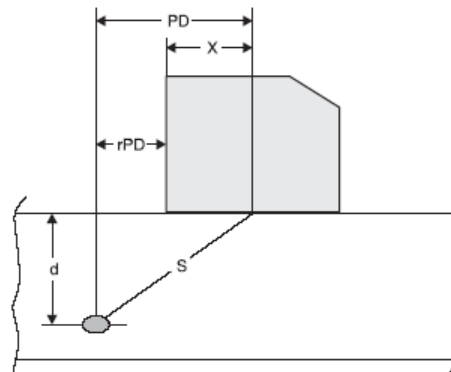

4.18 Probe Delay Calibration

Every probe has a delay line between the transducer element and the coupling face. This means that the initial pulse must first pass through this delay line before the sound wave can enter the test object. You can compensate for this influence of the delay line in the function P-DELAY.



If the value for P-DELAY is not known, read Chapter 5 in order to determine this value.

4.19 Setting the Angle of Incidence

The ANGLE function enables you to adjust the angle of incidence of your probe for the material used. This value is required for the automatic calculation of the flaw position. The angle of incidence for the straight-beam probe is fixed to 0°.



Adjustment range: 0° ~80°

4.20 Magnifying the Contents of a Gate

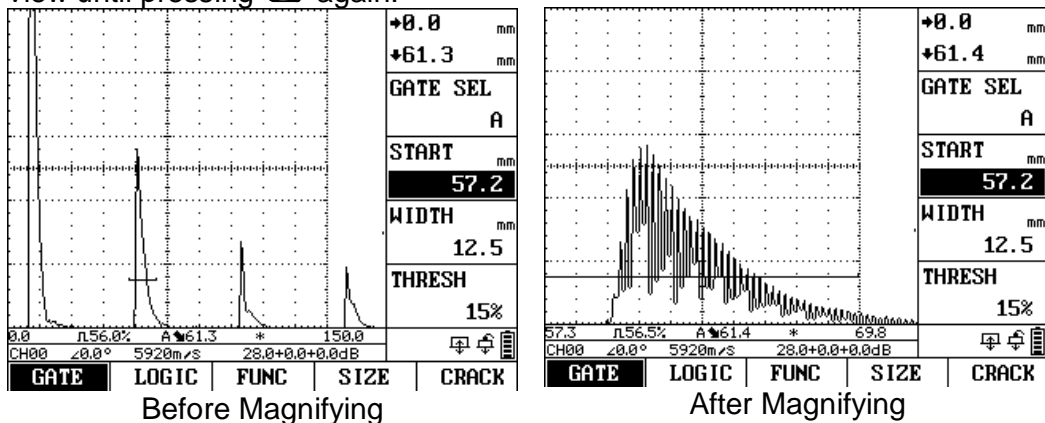
Whenever an A-Scan is active, pressing the  key enlarges the displayed portion of the A-Scan contained in the selected gate. Any of the available gates may be specified as the selected gate. The width of the magnified gate determines the level of magnification since the display is magnified until the gate width equals the full-screen width. The display will contain the magnified view until pressing  again.



4.21 Freezing the A-Scan Display

Whenever an A-Scan is active, pressing  freezes the A-Scan display. The active A-Scan will remain as it appeared when  was pressed and the display will remain frozen until  is pressed again.

4.22 Setting the Display Grid

- Activate the SYS submenu (located in the CFG menu) by pressing the menu key below it. Three functions will appear down the right side of the display screen.
- Press the function key next to the selection titled GRID.
- To change the grid type, continue pressing the function key or turn the knob. Each grid style is shown in the display screen's A-Scan window as

- it is selected. You'll note that the following styles are available:
 - I G1-Ten major horizontal and five vertical divisions.
 - I G2-Two major horizontal and vertical divisions.
 - I G3-No on-screen grid. Only display-edge marks are visible.
- The grid style will be set to the last one displayed.

4.23 Selecting Units

In the function UNITS you can choose your favorite units between mm or inch.

- Activate the SYS submenu (located in the CFG menu) by pressing the menu key below it. Three functions will appear down the right side of the display screen.
- Press the function key next to the selection titled UNITS. You'll note that the following options are available:
 - I METRIC-metric unit system.
 - I IMPERIAL-Imperial unit system
- To change the units of measurements, repeatedly pressing the corresponding function key or by means of the knob.
- The unit of measurement will be set to the choice last displayed.

4.24 Scale Setting

As an alternative to the measured values, the instrument enables to display a scale in the measurement line. The scale gives you an overview of the position of echoes. You have a choice between a dimensionless ten-division scale and a scale showing the real position of the echoes.

The following settings are possible:

- I S-PATH: Display of sound path scale
- I P-D: Display of projection distance scale
- I DEPTH: Display of depth distance scale
- I DIV: Display of a dimensionless scale
- I RANGE: Display of Range scale

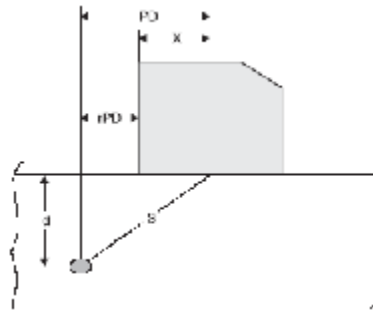

Select the function SCALE. Then use the knob to set the required display mode. As an alternative, you can repeatedly press  to switch the scale.

4.25 Fill function

The function FILL toggles between the filled and the normal echo display mode. The filled echo display mode improves the echo perceptibility due to the strong contrast, especially in cases where workpieces are scanned more quickly.

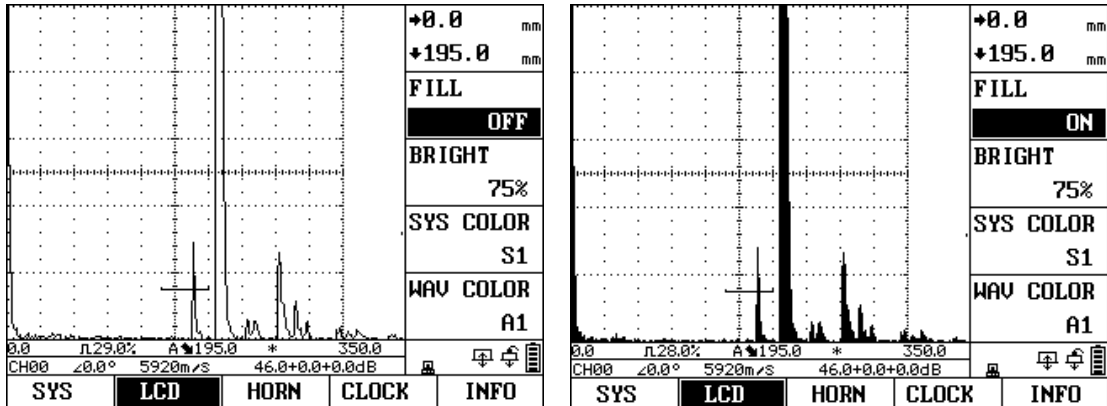

4.26 Setting the Display Brightness

Use the function BRIGHT to set the display brightness. You can choose between four brightness options: 25%, 50%, 75% and 100%.

- Activate the LCD submenu (located in the CFG menu) by pressing the menu key below it. Four functions will appear down the right side of the display screen.
- Press the function key next to the selection titled BRIGHT.
- To change the brightness level, continue pressing the function key or turn the knob.
- The display brightness will remain at the level last displayed.

Note: For the 25% option, the instrument consumes less current and consequently increases the operating time in battery operation.

4.27 Setting the Display Color

The SYS COLOR value determines the color of the background, the gate and the DAC/AVG curves. All color schemes are recommended for indoor operation while S0 and S3 are best suited for outdoor operation.

- Activate the LCD submenu (located in the CFG menu) by pressing the menu key below it. Four functions will appear down the right side of the display screen.
- Press the function next to the selection titled SYS COLOR. There are nine preset color schemes.
- To change the display's color scheme, continue pressing the function key or turn the knob.
- The display color will remain at the scheme last displayed.

4.28 Setting the A-Scan Color

- Activate the LCD submenu (located in the CFG menu) by pressing the menu key below it.
- Press the function key next to the selection titled WAV COLOR. There are eight A-Scan color options.
- To change the A-Scan's color, continue pressing the function key or turn the knob.
- The A-Scan echo will remain the color last displayed.

4.29 Key Sound

The key sound can be turned on or off using the KEY SOUND function located in the HORN submenu.

4.30 Date and Time Setting

For a correct documentation you should always make sure that you are using the correct date and time setting.

- Activate the CLOCK submenu (located in the CFG menu) by pressing the menu key below it. Two functions will appear down the right side of the display screen.
- Press the function key next to the function Y-M-D. The date is displayed in Year-Month-Day format. Note that the first time you press the function key, the year item is highlighted. The next time you press the function key, the month item is highlighted. Finally, pressing the function key again will cause the day item to be highlighted.
- To change the year, month or days, turn the knob while the desired item is highlighted.
- When complete, press the function one more time. The current date will be set to the date displayed.

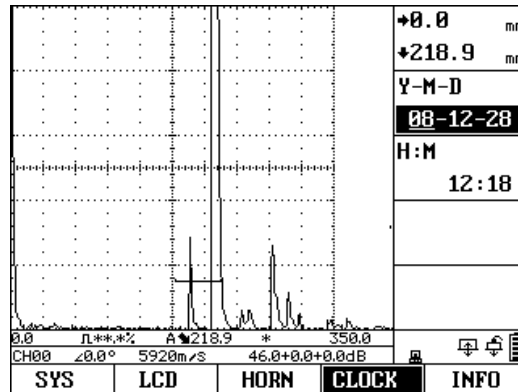

Time is displayed in Hour-Minute format. And the time setting procedure is similar to that of the date.

Once set, the internal clock of the instrument will maintain the current date and time.

4.31 Display the System Information

You can enter the INFO submenu to see the software version and the serial number of the instrument.

The VERSION and the S/N values are read-only. They cannot be modified by the user.

4.32 Resetting the Instrument

In case the instrument can no longer be operated, or you need to make a basic initialization (factory setting), you can reset the instrument.

The instrument can be reset by the SYS RESET function. All the memory data, including the wave files, the channel files and the video files, will be cleared during system reset. And the instrument settings will be reset to default.

To reset the instrument

- Activate the RESET submenu (in the MEM menu) by pressing the menu key below it.
- Press the function key next to the SYS RESET function.
- Continue pressing the function key or turn the knob to trigger the reset

action. It will prompt out “Reset system to original ?”. Press the menu key below YES to confirm the reset operation. Or press the menu key below NO to cancel the reset operation.

NOTE:

- I The effects of resetting the instrument may not be reversed.
- I No key action should be performed during resetting process.

4.33 Connecting to a Computer

The instrument is equipped with a USB port at the upper left of the instrument. The PC can connect with the instrument via the USB port. A-Scan display, instrument settings, and videos stored in the memory of the instrument can be transferred to the computer through the USB port. Detailed information of the communication software and its usage refer to the software manual.

5 Calibration and Measurement

Before working with the instrument, you have to calibrate the instrument: you have to adjust the material velocity and display range and allow for the probe delay depending on the material and dimensions of the test object.

To ensure a safe and proper operation of the instrument, it is necessary that the operator be adequately trained in the field of ultrasonic testing technology.

Below you will find some examples of common calibration methods for certain test tasks.

5.1 Calibration with Straight- and Angle-Beam Probes

Case A: With Known Material Velocity

Calibration process

- Set the known material velocity in VELOCITY.
- Couple the probe to the calibration block.
- Set the required display range in RANGE. The calibration echo must be displayed on the screen.
- Position the gate on one of the calibration echoes until the sound path of the echo is indicated in the measurement line.
- After this, change the adjustment of the function P-DELAY until the correct sound path for the selected calibration echo is indicated in the measurement line.

Example:

You are carrying out the calibration for the calibration range of 300 mm via the function group BASE using the calibration block DB-P (thickness 225 mm) which is laid flatwise.

- Set RANGE TO 300 mm.
- Set the known material velocity of 5920 m/s in VELOCITY.
- Set the gate so that it is positioned on the first calibration echo (from 225 mm).
- Read the sound path in the measurement line. If this value is not equal to 225 mm, change the adjustment for the function P-DELAY until it is at 225 mm.

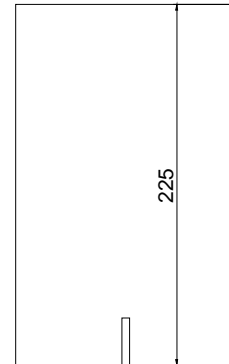

This completes the calibration of the instrument to the material velocity of 5920 m/s with a calibration range of 300 mm for the straight-beam probe used.

Case B: With Unknown Material Velocity

Use the semiautomatic calibration function of the instrument via the function group CAL for this calibration case.

The distances between 2 calibration echoes must be entered as default data. The instrument will then carry out a plausibility check, calculate the material velocity and the probe delay, and automatically set the parameters.

Calibration Process

- Set the required display range in RANGE. The two calibration echoes selected must be displayed on the screen. Set the range so that the second calibration echo is located on the right edge of the screen.
- Select the function group PDELAY.
- Enter the distances of the two calibration echoes in S-REF1 and S-REF2.
- Position one gate on the first calibration echo.
- Position the other gate on the second calibration echo.
- Press the function key next to the selection CAL to trigger the calibration.

The correct calibration is confirmed by the message "Calibration is finished". The instrument will now automatically determine the sound velocity and the probe delay and set the corresponding functions accordingly. The value of the function P-DELAY will be set to the correct value.

If the instrument is not able to carry out any valid calibration on the basis of the input values and the echoes recorded, a corresponding error message is displayed. In that case, please check the values of your calibration lines and repeat the process of recording the calibration echoes.

Example:

- Enter the distances (thicknesses) of the two calibration lines S-REF1 (225 mm) and S-REF2 (450 mm).
- Position one gate on the first calibration echo.
- Position the other gate on the second calibration echo.

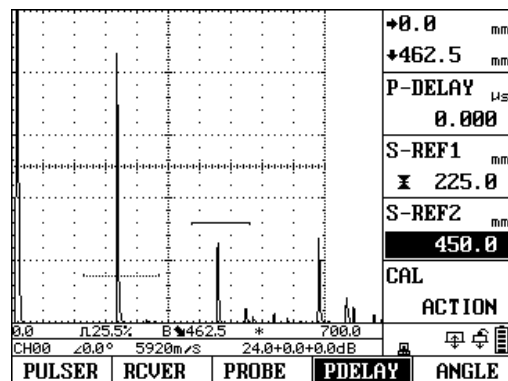

- Press the function key next to the function CAL to carry out the calibration.

The valid calibration is briefly confirmed and carried out.

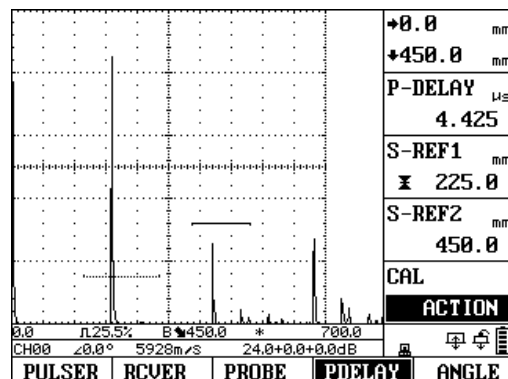

5.2 Calibration with Dual-Element (TR) Probes

Dual-element (TR) probes are especially used for wall thickness measurement. The following peculiarities must be taken into account when using these probes:

Echo Flank. Most dual-element (TR) probes have a roof angle (transducer elements with inclined orientation toward the test surface). This causes mode conversions both at beam index (sound entry into the material) and at the reflection from the backwall, which can result in very jagged echoes.

V-Path Error. Dual-element (TR) probes produce a v-shaped sound path from the pulser via the reflection from the backwall to the receiver element. This so-called “V-path error” affects the measuring accuracy. You should therefore choose two wall thicknesses that cover the expected thickness measurement range for the calibration. In this way, the V-path error can be corrected to the greatest possible extent.

Higher Material Velocity. Due to the V-path error, a higher material velocity than that of the test material is given during calibration, especially with small thicknesses. This is typical of dual-element (TR) probes and serves for compensation of V-path error.

With small wall thicknesses, the above-described effect leads to an echo amplitude drop which has to be especially taken into account with thicknesses less than 2 mm.

A stepped reference block having different wall thicknesses is required for calibration. The wall thicknesses must be selected so that they cover the expected readings.

Calibration Process

We recommend to use the semiautomatic calibration function for the calibration with T/R probes.

- Set the required test range
- Increase the probe delay until the two calibration echoes selected are displayed within the range
- Set the pulser and receiver functions according to the probe used and the test application.
- Select the function group PDELAY.
- Enter the distances of the two calibration echoes in S-REF1 and S-REF2.
- Position one gate on the first calibration echo.
- Position the other gate on the second calibration echo.
- Press the function key next to the selection CAL to trigger the calibration.

The correct calibration is confirmed by the message “Calibration is finished”. The instrument will now automatically determine the sound velocity and the probe delay and set the corresponding functions accordingly. The value of the function P-DELAY will be set to the correct value.

If necessary, check the calibration on one or several known calibration lines, e.g. using the stepped reference block.

1.

5.3 Distance Amplitude Curve

The instrument is available with Multi-Curve Distance Amplitude Curve (DAC) function. Functions for the distance-amplitude curve are accessed through the DAC Menu, which is located by pressing .



When displayed, the DAC curve visually represents a line of constant reflector peaks over a range of material depths. A new feature of the instrument is a multiple-curve option that displays three dB offset DAC curves simultaneously. Each curve represents constant reflector size at varying material depth. Remember that in DAC mode, the only deviation from traditional display and operation is the appearance of the DAC curve. All A-Scan echoes are displayed at their non-compensated height.

A DAC curve is programmed using a series of same-reflector echoes at various depths covering the range of depths to be inspected in the test material. Because near field and beam spread vary according to transducer size and frequency, and materials vary in attenuation and velocity, DAC must be programmed differently for different applications. A DAC curve can be based on up to 16 data points (material depths). These points are recorded from the DAC menu as described below.

Recording the DAC Curve

DAC Curve points are typically taken from a standard with equally sized reflectors (holes) located at various material depths. The primary echo from each of these points (for up to a total of 16 echoes) are recorded. When DAC is active, the instrument displays a curve that represents echo peaks for constant reflectors at varying material depth.

Before starting to record a reference curve, the instrument must be correctly calibrated. To program the DAC Curve:

- Access the DAC menu by pressing , then select the DAC submenu by pressing the menu key below it.
- Press the function key next to the PROGRAM function. Repeatedly press the PROGRAM function key or turn the knob to Trigger the DAC program. When DAC program is triggered, "DAC" and a digit number indicating the point index appears on the top right corner of the display.
- Couple the probe to the first reference point and adjust the gate so that it is broken by the primary echo. If necessary, adjust the gain so that the echo crosses the gate and the highest peak in the gate is at approximately 80% of full-screen height. The highest peak must not be higher than 100% full-screen height. Note that you can press  or  to search the next echo very quickly.
- While the gate is lined up over the first reference echo, press the key next to the RECORD function. Continue to press the key next to the RECORD function to record the first DAC Curve point. Note that the largest echo to cross the A-Gate will be treated as the reference echo. The gain value at which this point is recorded becomes the "baseline" gain value.
- Continue to record additional curve points up to a maximum of 16 points (note that at least two DAC Curve points are required). As soon as you have recorded at least two curve reference points, your DAC is already



active.

- When complete press the key next to FINISH and follow the on-screen prompts to exit the DAC program.

Note that stored DAC curve points can be edited as described in next section.

Editing DAC Curve

After reference points are recorded, their values may be manually adjusted, or some points may be manually deleted. To edit or delete points:

- With the DAC menu accessed, select EDIT submenu.
- Press the function key next to the EDIT function. Continue to press the function key or turn the knob to start the EDIT process. When DAC EDIT process is triggered, "DAC" and a digit number appear indicating the point index on the top right corner of the display.
- Press  or  to select the point to edit.
- To adjust a point's height-Press the function key next to the ADJUST function. Turn the knob clockwise or anticlockwise to adjust the point's echo height.
- To delete a point – Press the function key next to the DELETE function. Continue to press the function key or turn the knob to delete that point from the DAC records.
- When complete press the function key corresponding to FINISH and follow the on-screen prompts to finish the editing.

Creating DAC Offset Curves

When operating with DAC turned on, three DAC curves including RL, SL and EL are typically displayed. The three curves can be offset from the original DAC curve (ML) by a user-inputted amount.

- Select the function DAC-RL (or DAC-SL, DAC-EL) located in the OFFSET submenu.
- Change the offset value by means of the knob.

The offset range from -50dB to 50dB.

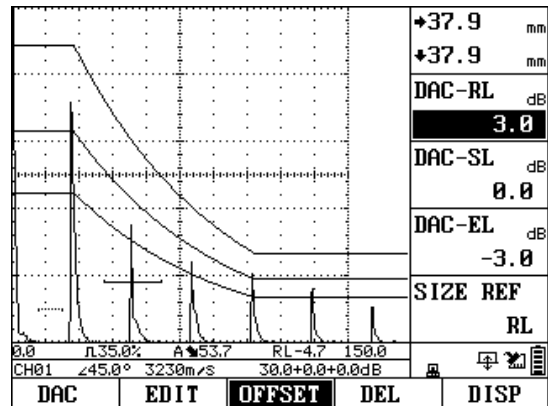

Specifying the DAC Reference Curve

Once the DAC curve is recorded and displayed (by turning DAC DISP on), echoes are automatically compared to the size reference curve, which can be specified in the SIZE REF selection. The options include RL, SL, EL, and ML. The dB equivalent height of the signal above or below the corresponding DAC Reference Curve amplitude is displayed as a comparison result.

The comparison result is shown as right figure.
 Note that the result is like: RL-3.9

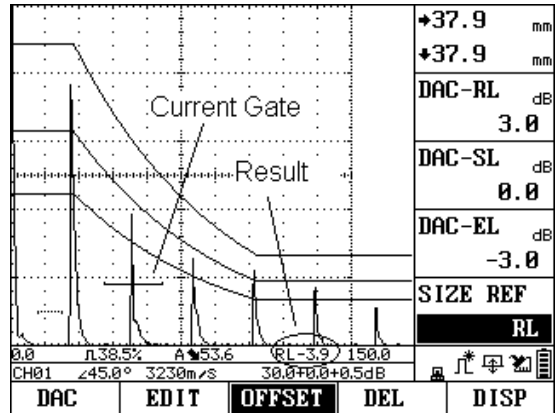

Deleting a DAC Curve

To delete a stored DAC curve

- With the DAC menu activated, select the DEL submenu.
- Press the function key next to the DEL DAC function.
- Press the function key next to the DEL DAC function a second time or turn the knob. Then confirm your selection.

Turning On/Off the DAC display

Turning DAC DISP On and Off causes the DAC curves to be displayed or removed.

- With the DAC menu activated, select the DISP submenu.
- Press the function key next to the DAC DISP function.
- Press the function key next to the DAC DISP function a second time or turn the knob to turn On/Off the DAC display.

Note that if the DAC curve is not created, it will prompt out “No DAC curve found” and DAC DISP will be set to OFF.

Echo Evaluation with DAC

In order to be able to evaluate a flaw indication by means of the DAC, certain conditions must be met.

- I The DAC must already be recorded.
- I It only applies to the same probe that was used when recording the curve. Not even another probe of the same type must be used.
- I The DAC only apply to the material corresponding to the material of the reference block.
- I All functions affecting the echo amplitude must be set the same way as they were when the curve was recorded.

5.4 Measuring with DGS/AVG

Using the AVG (the same as DGS) function, you can compare the reflecting power of a natural flaw in the test object with that of a theoretical flaw (circular disk-shaped equivalent reflector) at the same depth.

Note: You are comparing the reflecting power of a natural flaw with that of a theoretical flaw. No definite conclusions may be drawn on the natural flaw (roughness, inclined position, etc.).

The so-called AVG diagram forms the basis for this comparison of the reflecting

power. This diagram consists of a set of curves showing the correlation of three influencing variables:

- I Distance between the probe and circular disk-shaped equivalent reflector
- I Difference in gain between various large circular disk-shaped equivalent reflectors and an infinitely large backwall
- I Size of the circular disk-shaped equivalent reflector. The influencing variable always remains constant for one curve of the set of curves.

The advantage of the AVG method lies in the fact that you can carry out reproducible evaluations of small discontinuities. The reproducibility is most of all important, for example, whenever you aim to carry out an acceptance test.

Apart from the influencing variables already mentioned, there are other factors determining the curve shape: sound attenuation, transfer losses, amplitude correction value, probe and etc.

The following probe parameters affect the curve shape:

- I Element or crystal diameter
- I Frequency
- I Delay length
- I Delay velocity

You can adjust these parameters on the instrument in such a way that you can use the AVG method with many different probes and on different materials.

Note: Before setting the AVG function, the instrument must first be calibrated because all functions affecting the AVG evaluation mode (VELOCITY, P-DELAY, DAMPING, ENERGY, P-WIDTH, XTL FREQ, EFF DIAM, RECTIFY) can no longer be changed after the reference echo has been recorded.

Settings for the AVG measurement

Before using the AVG feature to evaluate reflectors in test pieces, the characteristics of the attached probe must be specified, certain characteristics of the reference standard must be input, and a reference echo must be stored. You must select the REF submenu and input the characteristics for the probe you've connected including:

- XTL FREQ- The probe's frequency rating
- EFF DIAM – The probe element's effective diameter rating

Record the Reference Echo that Defines the AVG Curve

Prior to generating the AVG curve, a test standard with a known reflector must be used to define a reference point. Acceptable test standards include these reference types:

- I BW – Backwall echo with reference defect size defined as infinity
- I SDH – Side Drilled Hole with a reference defect size defined as the hole's diameter.
- I FBH – Flat Bottom Hole with a reference defect size equal to the hole's facial diameter.

Follow these steps to record a reference echo:

- Select the REF submenu, then the REF TYPE function. This function allows you to select one of the three reference types described above.
- Select the REF SIZE function, and specify the size of the known

- standard's reference flaw.
- Select the AVG submenu, then the PROGRAM function. Turn the knob to start the AVG program. When AVG program is triggered, "AVG" appears indicating the point index on the top right corner of the display.
- Couple the probe to the known standard, capture the reference flaw so that its reflected echo is displayed on the instrument's A-Scan, and adjust selected Gate's starting point to ensure that the resulting echo triggers the gate.
- Adjust the gain until the reference flaw's A-Scan peak measures 80% of FSH (Full Screen Height).
- With the probe coupled to the standard, and the reference flaw's echo captured by selected Gate, press the function key next to the RECORD function to record an AVG reference echo.
- After the AVG reference echo is recorded, its value may be manually adjusted using the ADJUST function.
- When complete press the key next to FINISH and follow the on-screen prompts to exit the AVG program.

Note that only one AVG reference echo can be stored at a time. To delete the currently stored reference

- Access the DEL submenu
- Select DEL AVG, and then follow the on-screen prompts.

Once a reference echo has been recorded, the AVG curves (the AVG-UL, the AVG-ML and the AVG-DL) are automatically displayed using default settings.

Creating AVG Offset Curves

When operating with AVG turned on, three AVG curves including the AVG-UL, the AVG-ML and the AVG-DL are typically displayed. The three curves can be offset by user-inputted equivalent flaw size values in the AVG-UL, AVG-ML and AVG-DL selection. The offset values will usually depend on the largest acceptable flaw size.

Deleting AVG Curve

To delete stored AVG curve

- With the AVG menu activated, select the DEL submenu.
- Press the function key next to the DEL AVG function.
- Press the function key next to the DEL AVG function a second time or turn the knob. Then follow the on-screen prompts to confirm the deleting.

Turning On/Off the AVG display

Turning the AVG DISP On and Off causes the AVG curve to be displayed or removed.

- With the AVG menu activated, select the DISP submenu.
- Press the function key next to the AVG DISP function.
- Press the function key next to the AVG DISP function a second time or turn the knob to turn On/Off the AVG display. Note that if the AVG curve is not created, it will prompt out "No AVG curve found" and AVG DISP

value will be OFF. Also note that switching this value to OFF does not delete the curve - it simply removes the curve from the display and disables the AVG mode.

Evaluating Test Samples in AVG Mode

Once the curve is recorded and displayed (by turning AVG DISP on), echoes are automatically compared to the AVG curve and evaluated based on the recorded reference. The result is shown as ERS (Equivalent Reflector Size), which evaluates the reflected echo and calculates the equivalent reflector size.

This is shown in right figure.
Note that the ERS is $\Phi 2.1$ mm.

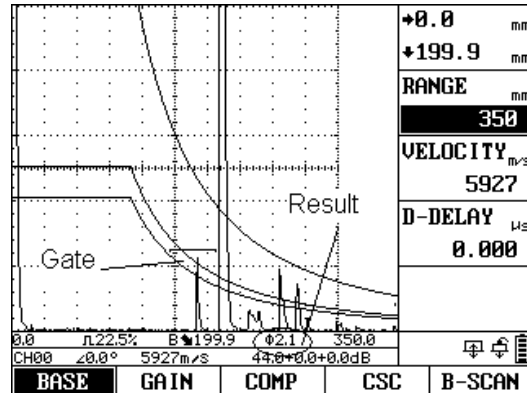

5.5 Curved Surface Correction

When using angle beam transducers on a curved surface the instrument will calculate the surface distance and depth of defect, taking into account the internal or external radius.

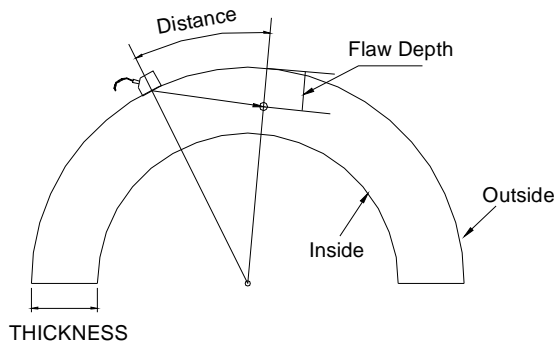

THICK: Use the THICK function to set the material's wall thickness. This value is required for the automatic calculation of the real depth.

Adjustment range: 10~5000 mm

O-DIAM (Outside diameter of the test object): You will need the CSC function for tests on circular curved surfaces, for example when testing longitudinally welded tubes. In order to make the instrument carry out the corresponding correction of (reduced) projection distance and depth, you should enter the outside diameter of your test object in this function.

Adjustment range: 2~5000 mm

CSC: If you plan to carry out the flaw position calculation for the curved surface workpieces, the CSC function should be turned on. Otherwise turn off the CSC function.

5.6 Flaw Sizing Feature

Using the Flaw Sizing feature, you can calculate the equivalent size of the flaw

easily and quickly.

- Position the selected gate over the echo from the backwall of the workpiece.
- Activating the SIZE submenu locating in the GATE menu by pressing the corresponding key below it.
- Select the BACK GAIN function. Then press the corresponding function key next to it to trigger the back-echo recording and analysis process. The instrument will record the echo and calculate the required gain sensitivity automatically. And then the instrument will automatically adjust the gain to the calculation result.
- Position the selected gate over the echo from the flaw.
- Select the CALC function. Then press the corresponding function key next to it to calculate the equivalent size.

The calculation result (the equivalent size of the flaw) will be displayed in the CALC bar.

5.7 Crack Height Measuring Feature

This feature allows measuring the height of a crack found inside the workpiece. Before starting to use the Crack Height Measure function, the instrument and the probe must be correctly calibrated.

- Activate the CRACK submenu locating in the GATE menu by pressing the corresponding key below it.
- Position the selected gate over the echo from the first point of the crack. Then record this position using the A-POINT function.
- Position the selected gate over the echo from the second point of the crack. Then record this position in the B-POINT function.
- The instrument will automatically calculate the crack height using the recorded parameters and displays the result in the HEIGHT bar.

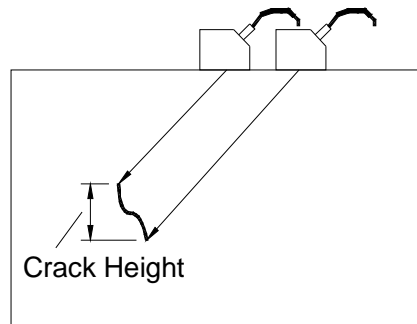

5.8 Envelope Function

When the Envelope function is activated, the echoes with the highest amplitude within selected gate will be recorded and displayed statically on the screen additionally to the live A-Scan. And the  icon will appear near the down right of the display.

To activate the Envelope function

- Activate the FUNC submenu (located in the GATE menu) by pressing the menu key below it.
- Press the function key next to the selection titled ENVELOPE.
- To turn on/off the ENVELOPE function, continue pressing the function key or turn the knob.

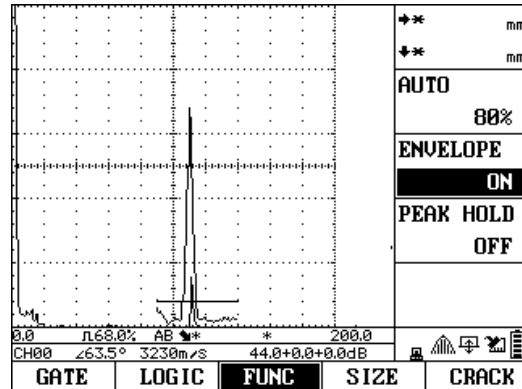

Also you can continue pressing  to turn on/off the Peak Hold function. Note that Peak Hold and Envelop cannot function simultaneously.

5.9 Peak Hold Feature

When Peak Hold is activated, the echo with the highest amplitude in the selected gate becomes the reference echo displayed statically on the screen additionally to the live A-Scan. And the  icon will appear near the down right of the display. You can use this function to record and document the peaked, maximum echo display.

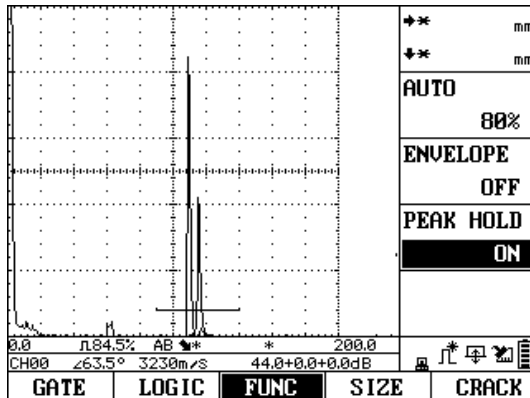

To activate the Peak Hold Feature

- Activate the FUNC submenu (located in the GATE menu) by pressing the menu key below it.
- Press the function key next to the selection titled PEAK HOLD.
- To turn on/off the Peak Hold function, continue pressing the function key or turn the knob.

Also you can continue pressing  to turn on/off the Peak Hold function. Note that Peak Hold and Envelop cannot function simultaneously.

5.10 B-Scan Feature

In B-Scan mode, the instrument displays a graphical cross-section of the workpiece.

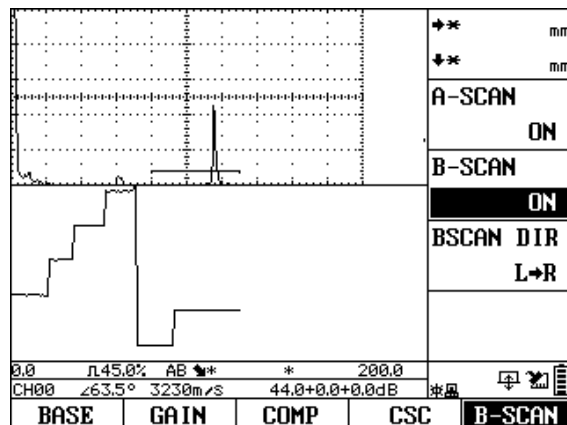

Use the following procedure to switch to B-Scan mode.

- Select the B-SCAN function.
- Switch the value to ON by means of the knob.
- Use the BSCAN DIR function to set the scan-display direction.

5.11 Data Storage

The instrument is equipped with a data-storage system. A-Scans patterns, instrument settings, and video can be stored in data files for later retrieval. File data can be saved, recalled and deleted by using the MEM menu.

Wave Files

Wave files are used to store A-Scan pattern, along with the instrument settings. Data in the wave files can be stored, recalled and erased.

Wave STORE

You can save the A-Scan pattern to a wave file using the STORE function.

- Select the function FILE.
- Use the knob to set the file name where you would want to store the current A-Scan pattern (F000~F999).
- Select the function STORE
- Use the knob or repeatedly press the corresponding function key to trigger the STORE operation.

Note:

The asterisk (*) before a selected file name indicates that this file is already occupied. It is not possible to overwrite an occupied file; select another file name which is still empty, or clear the occupied file. To avoid loss of data e.g. in case of a software update you should save the file to a PC.

Wave RECALL

You can recall a stored wave file; your instrument will then display all the test-relevant technical features that existed at the moment of the setup. A frozen display of the stored A-Scan appears.

Wave CLEAR

An occupied file is marked with an asterisk (*) before the file name. You can clear the file if you no longer need them. Wave Files are cleared using the CLEAR function.

- Select the function FILE.
- Use the knob to set the file name to clear (F000~F999).
- Select the function CLEAR.
- Use the knob or repeatedly press the corresponding function key to trigger the CLEAR operation. It will then prompt: Clear wave file?
- Confirm by pressing the corresponding key one more time.

The file is now cleared; the asterisk preceding the file name is no longer there.

Channel Files

Channel files (CH00~CH99) are used to store a specific instrument setup configuration. This means that whenever you recall a stored channel file, your instrument is again set up exactly the same as it was at the moment when the file was stored. This makes each one of your tests reproducible. You will find the following functions:

Channel STORE

To store instrument settings in a channel file follow this procedure

- Activate the CHANNEL submenu (located in the MEM menu) by pressing the menu key below it.
- Press the function key next to the selection titled FILE. Then change the file name to the one you desire by turning the knob. Note that if the file is not empty, an icon of “*” will appear before the file name and data can’t be saved to this file.
- Press the function key next to the selection titled STORE. Perform the store operation by pressing the function key once more or turning the knob. If the store operation is successful, it will prompt out: “Data saved”. Note that if the channel file is not empty, the store operation will be canceled and prompt out a message: Error: This channel is not empty. You should change the FILE to an empty file to store the instrument settings.

Channel RECALL:

When the channel file is recalled, all instrument settings are modified to match the settings stored in the channel file. Once a channel file is opened, instrument settings may be modified from their channel file configurations. If necessary, save the current instrument setup to a new channel file before loading a channel file.

Channel CLEAR:

Channel files are cleared using this procedure:

- Activate the CHANNEL submenu (located in the MEM menu) by pressing the menu key below it.
- Press the function key next to the FILE function. Turn the knob until the desired file name appears.
- Press the function key next to the CLEAR function. Continue pressing the function key or turn the knob to perform the file CLEAR function. It will prompt out :“Clear this channel?. Press the menu key below YES to confirm the operation, or press the menu key below NO to cancel the operation.



Note:



The deleted file may not be retrieved.

The current settings of the instrument will be reset to default after the channel clear operation.

Video Files

Video file (DV01) is used to store a segment of video. To record a segment of video

- Activate the video recording operation by pressing . An icon  will appear in the status area when recording the video.
- To stop the recording, simply press  once more.

Note that the recording process will automatically end when the video file is full. Use RECALL function to RECALL a video file. The recalled video file will be shown at a fixed refresh rate. Press  to stop the show. Or press  to pause and restart the show.

RESET Function

You can clear all channels, all waves or all videos using the functions in the RESET submenu.

6 Maintenance and Care

6.1 Care of the Instrument

Clean the instrument and its accessories using a moist cloth. Only use the following recommended instrument cleaners: water, a mild household cleaner or alcohol (no methyl alcohol).

Attention:

Do not use any methyl alcohol, solvents, or dye penetrant cleaners!
The plastic parts can be damaged or embrittled by this.

6.2 Care of the Batteries

Capacity and life of batteries mainly depend on the correct handling. Please therefore observe the tips below.

You should charge the batteries in the following cases:

- I Before the initial startup
- I After a storage time of 3 months or longer
- I After frequent partial discharge

6.3 Maintenance

The instrument requires basically no maintenance.

Attention:

Repair work may only be carried out by authorized Service staff of us.

6.4 Warranty

When used in accordance with the manufacturer's written instructions and under normal operating conditions, the instrument is conditionally guaranteed to be free from defects in material and workmanship for a period of two years from date of shipment.

This warranty shall not apply to equipment subjected to misuse or abuse, improper installation, alteration, neglect, or accident. Excluded from this warranty are expendable items such as transducers, interconnecting cables, and batteries.

This warranty is limited to the original purchaser and is not transferable. No other warranty, expressed or implied, is made.

6.5 Tips on Safety



The design of the instrument meets safety standard. During the operation, it shall meet the specified external ambient condition, and the operator shall be furnished with concerned technology background, so as to guarantee safe operation.

Note:

1. *This instrument is a non-destructive inspection instrument for inspecting material, it is not allowed to use as a medical instrument.*
2. *The instrument is limited to be used in lab and industrial environment.*

Appendix

Appendix A: Charging the Batteries

The approximate level of remaining battery life is visually displayed by the battery indicator. When fresh batteries with full capacity are installed, the icon will appear as . As the battery life is consumed, the icon will begin to “empty”. When the battery indicator is almost empty as indicated by the symbol , charge the batteries as soon as possible. You may take a second battery pack or replacement battery pack with you if you cannot connect the instrument to mains.

The instrument automatically shuts off when batteries are too weak for reliable operation. Settings are saved and restored when the instrument is turned on again.

You can charge the lithium-ion battery pack either directly in the instrument or by means of an external battery charger provided with the instrument.

Attention:

You should only use the batteries provided by us and the corresponding battery charger. An improper handling of the batteries and of the battery charger may cause explosion hazard.

Internal Charging

Check the battery switch on the top of the instrument. Make sure to switch it on before internal charging.

If a battery pack is located in the instrument, the charging process is started automatically when you connect the plug-in power supply unit. You can carry out ultrasonic inspections and charge a battery at the same time.

The charging time is 10 hours with a simultaneous ultrasonic inspection. If the instrument is not being used for ultrasonic inspections, the charging time is 8 hours. This charging time applies to ambient temperatures from 25 to 30°C. Please take into consideration that the batteries are not charged to their full capacity at higher temperatures.

The PWR LED display at the top-right corner of the keypad indicates the status of the charging process. It will flash red/green during the charging process. And the flash will stop when the charging process stops.

External Charging

Lithium-ion batteries can be charged by means of an external battery charger.

- Take out the battery pack from the battery compartment of the instrument.
- Plug the charger’s power cord into a 100-240 VAC power source. Its Green indication lamp will illuminate when the charger is supplied with power.
- Push the adapter of the charger into the plug receptacle of the battery pack until it snaps into place. The green LED of the battery pack will light if the connection is properly aligned.
- When charging the battery pack, the battery pack’s RED indication lamp will light steadily.
- When charging is complete (typically after six to eight hours) the RED

indication lamp will shut off. You may remove the charger adapter from the battery pack.

- Reinstall the battery pack to the compartment of the instrument.

Note:

- I The battery switch on the top of the instrument must be set to ON for internal charging
- I The battery pack should be charged over a period of time, even not used.

Appendix B: Menu Structure

BASIC		P/R		GATE		MEM		CFG		DAC		AVG	
BASE	RANGE	PULSER	DAMPING	GATE	GATE SEL	WAVE	FILE	SYS	GRID	DAC	PROGRAM	AVG	PROGRAM
	VELOCITY		ENERGY		START		STORE		UNITS		RECORD		RECORD
	D-DELAY		P-WIDTH		WIDTH		RECALL		SCALE		ADJUST		ADJUST
			PRF		THRESH		CLEAR		FINISH		FINISH		
GAIN	GAIN	RCVER	PRB MODE	LOGIC	GATE MODE	CHANNEL	FILE	DISP	FILL	EDIT	EDIT	REF	XTL FREQ
	DB STEP		RECTIFY		B-LOGIC		STORE		BRIGHT		ADJUST		EFF DIAM
	OFFSET		REJECT				RECALL		SYS COLOR		DELETE		REF TYPE
					ALARM		CLEAR		WAV COLOR		FINISH		REF SIZE
COMP	T-CORR	PROBE	XTL FREQ	FUNC	AUTO	VIDEO	FILE	HORN	KEY SOUND	OFFSET	DAC-RL	OFF-SET	AVG-UL
			EFF DIAM		ENVELOPE				DAC-SL		AVG-ML		
			X-VALUE		PEAK HOLD		RECALL		DAC-EL		AVG-DL		
							CLEAR		SIZE REF				
CSC	CSC	PDELAY	P-DELAY	SIZE	BACK GAIN	RESET	CHANNELS	CLOCK	Y-M-D	DEL	DEL DAC	DEL	DEL AVG
	THICK		S-REF1		CALC		WAVES						
	O-DIAM		S-REF2				VIDEOS						
			CAL				SYS RESET						
B-SCAN	A-SCAN	ANGLE	ANGLE	CRACK	HEIGHT			INFO	VERSION	DISP	DAC DISP	DISP	AVG DISP
	B-SCAN		HL-DIAM		A-POINT				S/N				
	BSCAN DIR		HL-DEPTH		B-POINT								
			CAL										